

FITTING INSTRUCTION

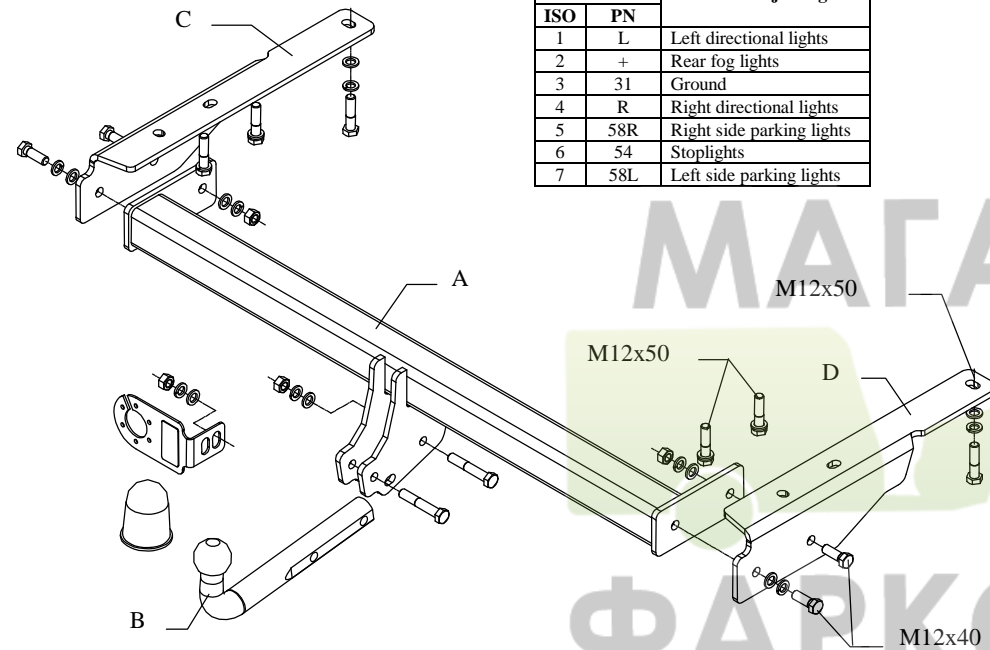

Clamp mark in acc. with		Cables joining
ISO	PN	
1	L	Left directional lights
2	+	Rear fog lights
3	31	Ground
4	R	Right directional lights
5	58R	Right side parking lights
6	54	Stoplights
7	58L	Left side parking lights

The instruction of the assembly

1. On the left and right side of chassis member unscrew four bolts (two per side) which fix a bumper.
2. To the left chassis member put element pos. C and to the right chassis member element pos. D in that way, so their holes agree with original threaded holes and screw all using bolts M12x50 (loosely).
3. Between fixed elements (pos. C and pos. D) slip main bar of towbar (pos. A) and screw using bolts M12x40.
4. Screw tow-ball (pos. B) and socket plate using bolts M12x100mm from equipment.
5. Tighten all bolts according to the torque shown in the table.
6. Connect electric wires of 7-bolts socket according to the instruction of the car. (Recommend to make at authorized service station)
7. Complete the paint coating damaged during installation.

This towbar is designed to assembly in following cars:
JEEP GRAND CHEROKEE (ZG), produced since 1992 till 02.1999, catalogue no. **JP03** and is prepared to tow trailers max total weight up to **3500 kg** and max vertical mass **125 kg**.

Foreword

Thank you for buying our product. This towbar is design according to rules of safety traffic regulations and their reliability has been confirmed in many tests. Reliability of towbar also depends on correct assembly and correct exploitation. For this reasons we kindly ask to read carefully this instruction and apply to hints.

The towbar should be install in points described by a car producer.

Torque settings for nuts and bolts (8,8):

M6 - 11 Nm	M8 - 25 Nm	M10 - 50 Nm
M12 - 87 Nm	M14 - 138 Nm	M16 - 210 Nm

NOTE

After install the towbar you should get adequate registration in registration book (at authorised service station).The car should be equipped with:

- Indicators
- Tow mirrors

After 1000km of exploitation check all bolts and nuts. The ball of towbar must be always kept clear and conserve with a grease.



PPUH AUTO-HAK S.J.

Produkcja Zaczepów Kulowych
Henryk & Zbigniew Nejman
76-200 SŁUPSK ul. Słoneczna 16K
tel/fax (059) 8-414-414; 8-414-413
E-mail: office@autohak.com.pl
www.autohak.com.pl

Towing hitch (without electrical set)

Class: **A50-X** Cat. no. **JP03**
Designed for:
Manufacturer: **JEEP**
Model: **GRAND CHEROKEE (ZG)**
produced since 1992 till 02.1999

Technical data:
D-value: 14,28 kN
maximum trailer weight: **3500 kg**
maximum vertical cup mass: **125 kg**

Approval number acc. to regulations EKG/ONZ 55.01: **E20-55R-01 1149**

Foreword

This towing hitch is designed according to rules of safety traffic regulations. The towing hitch is a safety component and can be install only by qualified personnel. Any alteration or conversion of the towing hitch is prohibited and would lead to cancellation of design certification. Remove insulating compound and underseal from vehicle (if present) in the area of the matting surfaces of the towing hitch. The vehicle manufacturer's specifications regarding trailer mass and max. vertical cup mass are decisive for driving whereat values for the towing hitch cannot be exceeded.

D-value formula:

$$\frac{\text{Max trailer weight [kg]} \times \text{Max vehicle weight [kg]}}{\text{Max trailer weight [kg]} + \text{Max vehicle weight [kg]}} \times \frac{9,81}{1000} = D \text{ [kN]}$$